

Valves ISO 5599/1

ISO 1, 5/2 - 5/3, electrically operated, with CNOMO pilot

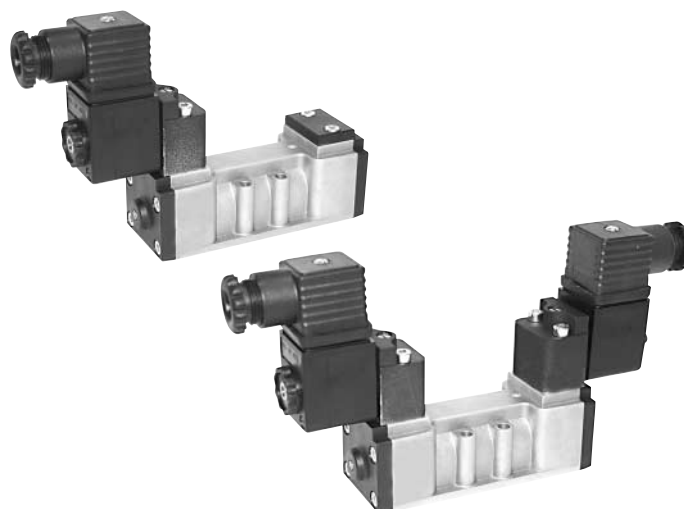

Executions			
Version	Symbol	Code	Item
5/2 solenoid/spring		032020	ISO1E50
5/2 solenoid/solenoid		032030	ISO1E51
5/2 solenoid/solenoid differential		032037	ISO1E52
5/3 with closed centres		032031	ISO1E70
5/3 with open centres		032032	ISO1E71
5/3 with pressurised centres		032043	ISO1E72
5/2 solenoid/spring external air pilot		032021	ISO1K50
5/2 solenoid/solenoid external air pilot		032044	ISO1K51
5/2 solenoid/solenoid differential external air pilot		032048	ISO1K52
5/3 with closed centres external air pilot		032049	ISO1K70
5/3 with open centres external air pilot		032053	ISO1K71
5/3 with pressurised centres external air pilot		032054	ISO1K72



Series of spool valves, conforming to ISO 5599/1 standards for the mounting only on sub-base, with CNOMO pilot.

Coils and connectors are to be ordered separately.

For the coils type ASA12.../ASA2... see page 2.200.1

For the connectors type A122... /A182... see page 2.210.20

For the sub-bases type SBA1... see page 2.120.1

2

Code key

Series	Size	Actuation	Function
ISO	1	E = electrical K = electrical with external air pilot	50 = 5/2 solenoid/spring
	2		51 = 5/2 solenoid/solenoid
			52 = 5/2 solenoid/solenoid differential
			70 = 5/3 CC
			71 = 5/3 CO
			72 = 5/3 CP

NOTE: FOR VALVES WITH PILOT IN LINE SEE PAGE 2.111.1



On request, they can be supplied according Directive 94/9/EC - ATEX

CE Ex II 2 GDc T5

Technical data			
Fluid	Compressed filtered air with or without lubrication. Lubrication, if be used, must be continous.		
Pressure range	0 ÷ 10 bar		
Temperature range	-10°C ÷ +60°C		
Orifice	8,5 mm		
Flow	800 NI/min at 6 bar with ΔP 1 bar		
Minimum piloting pressure	Monostable: 2 bar	Bistable: 1 bar	3 positions: 2 bar
Mounting	In any position		
Electropilot	Conforming to CNOMO		
Manual override	Bistable on solenoid pilot - Monostable on valve body		
Materials	Body:	Aluminium	
	Heads:	Plastic	
	Spool:	Aluminium	
	Distancers:	Plastic	
	Seals:	NBR	

Valves ISO 5599/1

ISO 1, 5/2 - 5/3, electrically operated, with CNOMO pilot

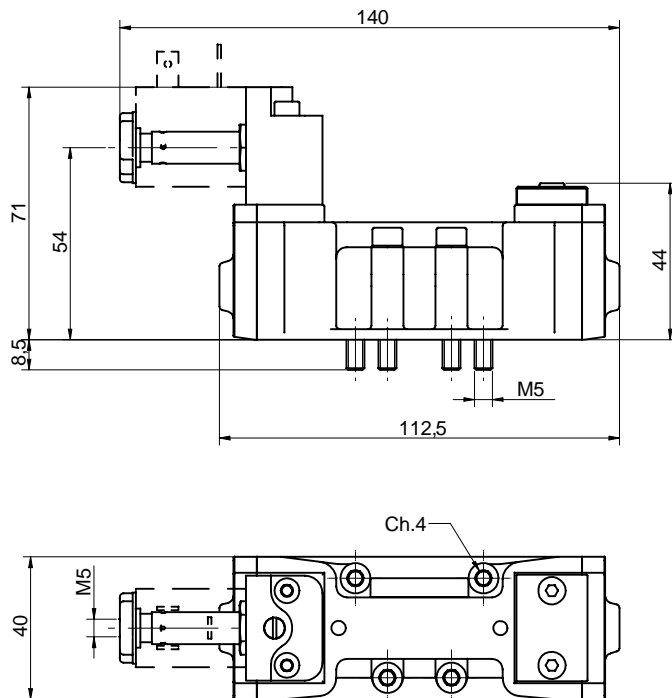

Version	Symbol	Code	Item
5/2 solenoid/spring		032020	ISO1E50
5/2 solenoid/spring external air pilot		032021	ISO1K50

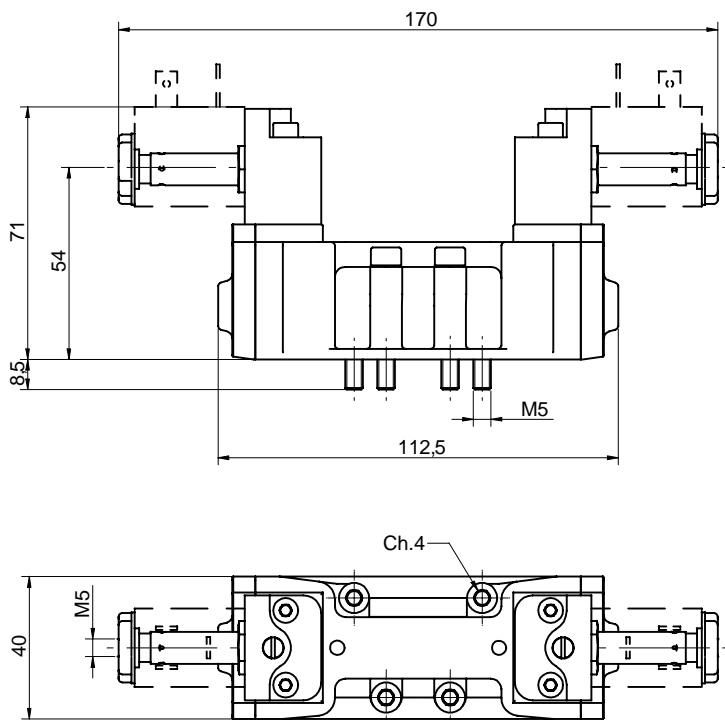

Version	Symbol	Code	Item
5/2 solenoid/solenoid		032030	ISO1E51
5/2 solenoid/solenoid differential		032037	ISO1E52
5/3 with closed centres		032031	ISO1E70
5/3 with open centres		032032	ISO1E71
5/3 with pressurised centres		032043	ISO1E72
5/2 solenoid/solenoid external air pilot		032044	ISO1K51
5/2 solenoid/solenoid external air pilot differential		032048	ISO1K52
5/3 with closed centres external air pilot		032049	ISO1K70
5/3 with open centres external air pilot		032053	ISO1K71
5/3 with pressurised centres external air pilot		032054	ISO1K72

Valves ISO 5599/1

ISO 1, 5/2 - 5/3, electrically operated, with IN LINE pilot



2

Execution			
Version	Symbol	Code	Item
5/2 solenoid/spring		032060	ISO1EL50
5/2 solenoid/solenoid		032070	ISO1EL51
5/2 solenoid/solenoid differential		032061	ISO1EL52
5/3 with closed centres		032071	ISO1EL70
5/3 with open centres		032072	ISO1EL71
5/3 with pressurised centres		032066	ISO1EL72
5/2 solenoid/spring external air pilot		032063	ISO1KL50
5/2 solenoid/solenoid external air pilot		032064	ISO1KL51
5/2 solenoid/solenoid differential external air pilot		032065	ISO1KL52
5/3 with closed centres external air pilot		032067	ISO1KL70
5/3 with open centres external air pilot		032068	ISO1KL71
5/3 with pressurised centres external air pilot		032069	ISO1KL72

Series of spool valves, conforming to ISO 5599/1 standards for the mounting only on sub-base, with IN LINE pilot.

Coils and connectors are to be ordered separately.

For the coils type ASA12.../ASA2... see page 2.200.1

For the connectors type A122... /A182... see page 2.210.20

For the sub-bases type SBA1... see page 2.120.1

Code key

Series	Size	Actuation	Function
ISO	1	EL = electrical	50 = 5/2 solenoid/spring
	2	KL = electrical with external air pilot	51 = 5/2 solenoid/solenoid
			52 = 5/2 solenoid/solenoid differential
			70 = 5/3 CC
			71 = 5/3 CO
			72 = 5/3 CP

NOTE: FOR VALVES WITH CNOMO PILOT SEE PAGE 2.110.1



On request, they can be supplied according Directive 94/9/EC - ATEX
CE **II 2 GDc T5**

Technical data			
Fluid	Compressed filtered air with or without lubrication. Lubrication, if be used, must be continous.		
Pressure range	0 ÷ 10 bar		
Temperature range	-10°C ÷ +60°C		
Orifice	8,5 mm		
Flow	800 NI/min at 6 bar with ΔP 1 bar		
Minimum piloting pressure	Monostable: 2 bar	Bistable: 1 bar	3 positions: 2 bar
Mounting	In any position		
Electropilot	IN LINE		
Manual override	Bistable on solenoid pilot - Monostable on valve body		
Materials	Body: Aluminium Heads: Plastic Spool: Aluminium Distancers: Plastic Seals: NBR		

Valves ISO 5599/1

ISO 1, 5/2 - 5/3, electrically operated, with IN LINE pilot

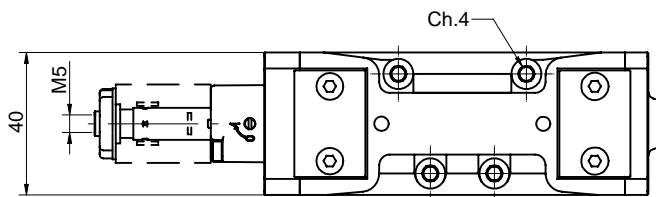
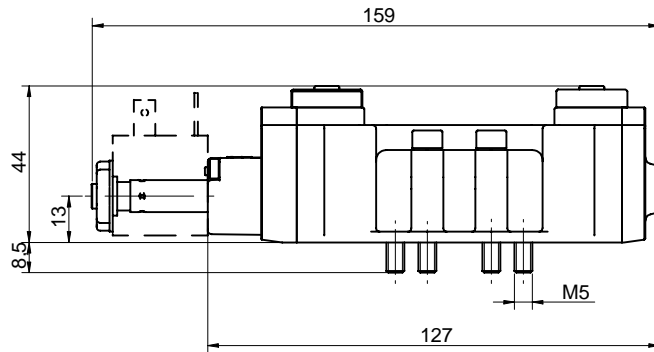

Version	Symbol	Code	Item
5/2 solenoid/spring		032060	ISO1EL50
5/2 solenoid/spring external air pilot		032063	ISO1KL50

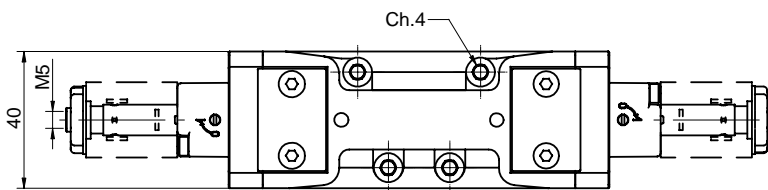
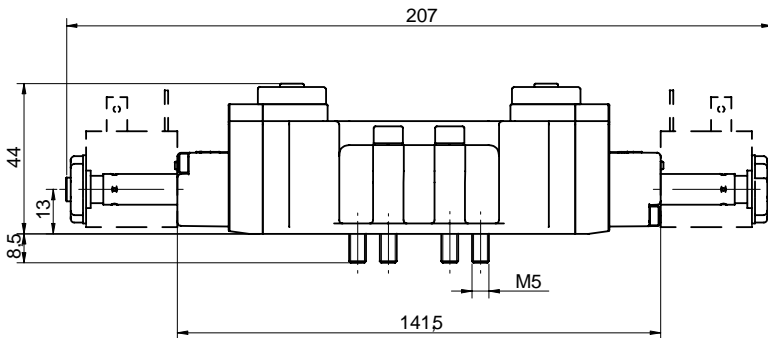

Version	Symbol	Code	Item
5/2 solenoid/solenoid		032070	ISO1EL51
5/2 solenoid/solenoid differential		032061	ISO1EL52
5/3 with closed centres		032071	ISO1EL70
5/3 with open centres		032072	ISO1EL71
5/3 with pressurised centres		032066	ISO1EL72
5/2 solenoid/solenoid external air pilot		032064	ISO1KL51
5/2 solenoid/solenoid external air pilot differential		032065	ISO1KL52
5/3 with closed centres external air pilot		032067	ISO1KL70
5/3 with open centres external air pilot		032068	ISO1KL71
5/3 with pressurised centres external air pilot		032069	ISO1KL72

Valves ISO 5599/1

ISO 1, 5/2 - 5/3, pneumatically operated



Executions			
Version	Symbol	Code	Item
5/2 solenoid/spring		032000	ISO1P50
5/2 solenoid/solenoid		032001	ISO1P51
5/2 solenoid/solenoid differential		032002	ISO1P52
5/3 with closed centres		032003	ISO1P70
5/3 with open centres		032004	ISO1P71
5/3 with pressurised centres		032019	ISO1P72

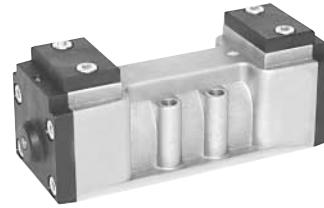

Series of spool valves, conforming to ISO 5599/1 standards for the mounting only ON sub-base.
For the sub-bases type SBA1... see page 2.120.1

Code key

Series	Actuation	Size	Function
ISO	1	P = pneumatic	50 = 5/2 solenoid/spring
	2		51 = 5/2 solenoid/solenoid
			52 = 5/2 solenoid/solenoid differential
			70 = 5/3 CC
			71 = 5/3 CO
			72 = 5/3 CP



On request, they can be supplied according Directive 94/9/EC - ATEX
CE **II 2 GDc T5**

Technical data			
Fluid	Compressed filtered air with or without lubrication. Lubrication, if be used, must be continuous.		
Pressure range	0 ÷ 10 bar		
Temperature range	-10°C ÷ +60°C		
Orifice	15 mm		
Flow	800 NI/min at 6 bar with ΔP 1 bar		
Minimum piloting pressure	Monostable: 2 bar	Bistable: 1 bar	3 positions: 2 bar
Mounting	In any position		
Manual override	Monostable on valve body		
Materials	Body:	Aluminium	
	Heads:	Plastic	
	Spool:	Aluminium	
	Distancers:	Plastic	
	Seals:	NBR	

Valves ISO 5599/1
 ISO 1, 5/2 - 5/3, pneumatically operated

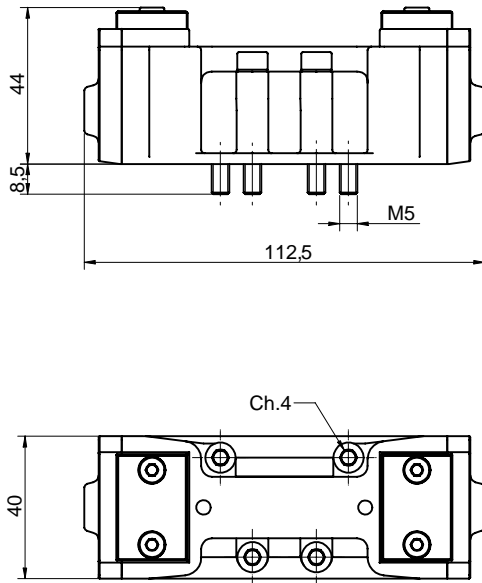

Version	Symbol	Code	Item
5/2 solenoid/spring		032000	ISO1P50
5/2 solenoid/solenoid		032001	ISO1P51
5/2 solenoid/solenoid differential		032002	ISO1P52
5/3 with closed centres		032003	ISO1P70
5/3 with open centres		032004	ISO1P71
5/3 with pressurised centres		032019	ISO1P72

Electrically and pneumatically operated valves ISO1 and ISO2

Sub-bases, ISO1



Executions			
Version	Symbol	Code	Item
Single sub-base		032190	SBA1S
Manifold sub-base		032120	SBA1M
Blank manifold end plate		032140	SBA1C
Ported manifold end plate		032141	SBA1A
Manifold blanking plate		032170	SBA1T
Interface for sub-base from size ISO1 to ISO2		032160	SBA1A2

The blank manifold end plate can be used to separate 2 supplies with different pressures on the same manifold.



On request, they can be supplied according Directive 94/9/EC - **ATEX**
CE **II 2 GDc T5**



Series of single and manifold sub-bases for valves ISO5599/1 size 1.

Materials:	Die-cast aluminium
	Seals: Nitrile rubber (NBR)
	Screws: Zinc plated steel

The kit SBA1M includes: 2 screws and 3 seals
 The kit SBA1C/A includes: 2 screws and 3 seals
 The kit SBA1T includes: 4 screws and 1 seal
 The kit SBA1A2 includes: 4 screws and 6 seals

type: **SBA1S**

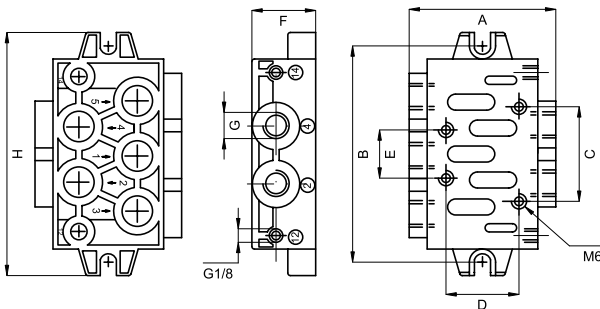

A	B	C	D	E	F	G	H
56	82,5	36	28	18	24	1/4"	92,5

type: **SBA1A2**

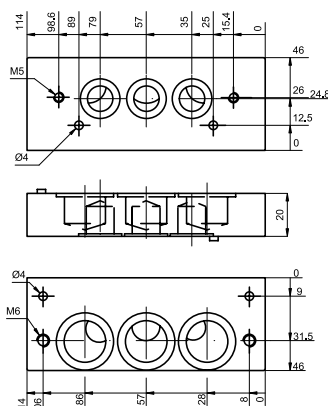

type: **SBA1M**

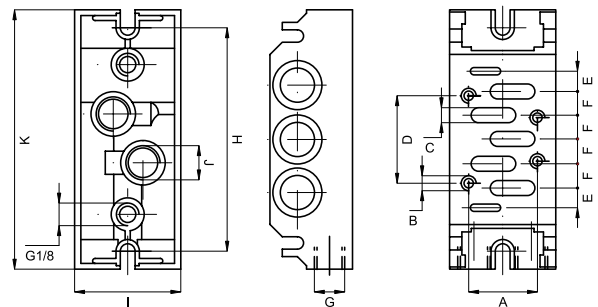

A	B	C	D	E	F	G	H	I	J	K
28	M5	4,5	36	8,5	9	1/4"	92	43	1/4"	106

type: **SBA1C**
SBA1A

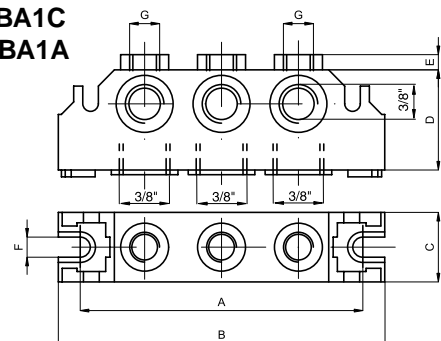

A	B	C	D	E	F	G
92	106	22	36	8	5,5	1/4"